

# 2.4

## Pilot Actuated Valves

Selected valves can be used for technical vacuum too.



Selected models are available for low temperature application.  
For detailed information refer to chapter 2.11.

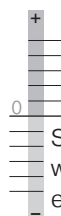

Selected models can be equipped with FKM seals for high temperature environment up to 120 °C.



**316** Selected models are available in stainless steel.  
For detailed information refer to chapter 2.12.

Selected models are available for explosion hazardous environment. They are ATEX-Ex certified.  
For detailed information refer to chapter 2.14.



# P 310 302/P 310 502

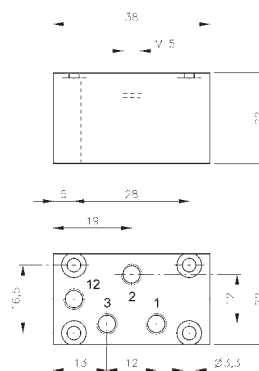
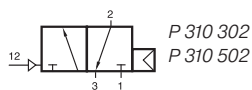

**P 310 302**

Pneumatically actuated 3/2-way spool valve with air spring return.

If pressure is attached to port 1 the function is normally closed.

If pressure is applied to port 3 the function is normally open.

Do not attach pressure at port 2.

Operating pressure and actuating pressure should be at the same level.

Exhaust can be throttled.

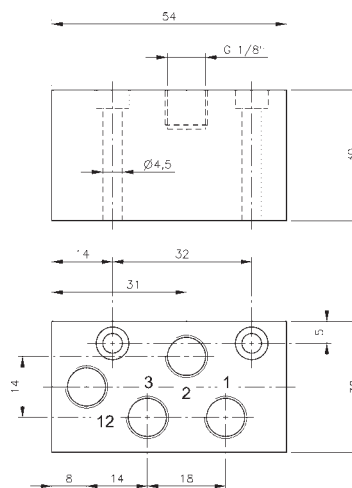

**P 310 502**

Type	Port size	Air flow	Operating press.	Actuating press.	Weight
P 310 302	M5	180 l/min	2 - 10 bar	the same	0,05 kg
P 310 502	G 1/8"	650 l/min	2 - 10 bar	the same	0,13 kg



P 310 501/P 310 701/P 310 801  
P 311 501/P 311 701/P 311 801

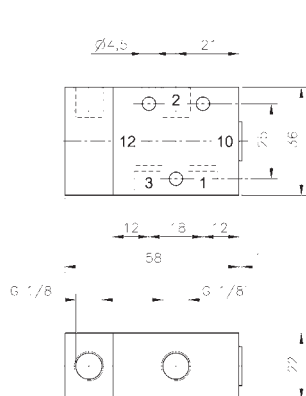

P 310 501/P 311 501

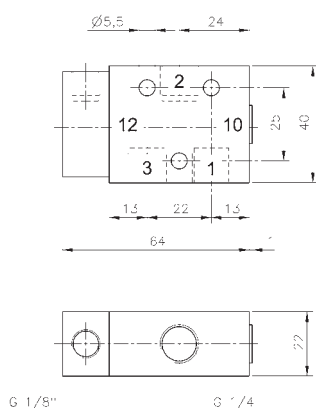

P 310 701/P 311 701

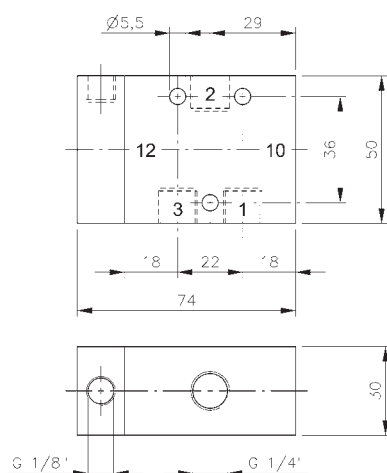

P 310 801/P 311 801

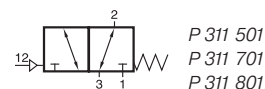
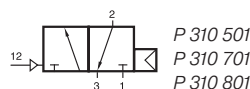

Pneumatically actuated 3/2-way spool valve.

Type P 310 \_\_\_ with air-spring-return.  
Operating pressure and actuating pressure should be at the same level. Pressure can be applied to port 1 (NC) or port 2 (NO).

Type P 311 \_\_\_ with mechanical spring return.  
Pressure can be applied to port 1 (NC), port 2 (NO) or port 3 (switch).

If 2/2-way is required, please use type P 311 \_\_\_\_.  
Ports can be fully plugged.

Exhaust can be throttled.

Type	Port size	Air flow	Operating press.	Actuating press.	Weight	
P 310 501	G 1/8"	650 l/min	2 - 10 bar	the same	0,13 kg	Ex
P 310 701	G 1/4"	1250 l/min	2 - 10 bar	the same	0,14 kg	Ex 316
P 310 801	G 1/4"	1450 l/min	1,5 - 10 bar	the same	0,29 kg	Ex
P 311 501	G 1/8"	650 l/min	1 - 10 bar	3 - 10 bar	0,13 kg	Ex
P 311 701	G 1/4"	1250 l/min	1 - 10 bar	3 - 10 bar	0,14 kg	Ex 316
P 311 801	G 1/4"	1450 l/min	1 - 10 bar	3 - 10 bar	0,29 kg	

# P 310 101/P 310 121/P 310 181 P 311 101/P 311 121/P 311 181

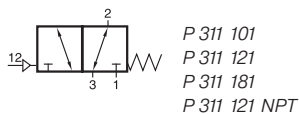
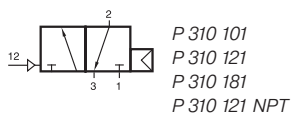

Pneumatically actuated 3/2-way spool valve.

Type P 310 \_\_\_ with air-spring-return.  
Operating pressure and actuating pressure should be at the same level. Pressure can be applied to port 1 (NC) or port 2 (NO).

Type P 311 \_\_\_ with mechanical spring return.  
Pressure can be applied to port 1 (NC), port 2 (NO) or port 3 (switch).

If 2/2-way is required, please use type P 311 \_\_\_.  
Ports can be fully plugged.

Exhaust can be throttled.

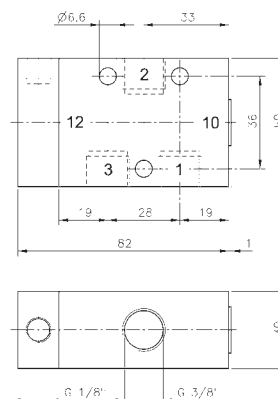

**P 310 101/P 311 101**

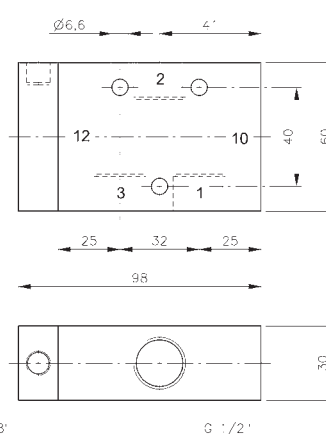

**P 310 121/P 311 121  
P 310 121 NPT/P 311 121 NPT**

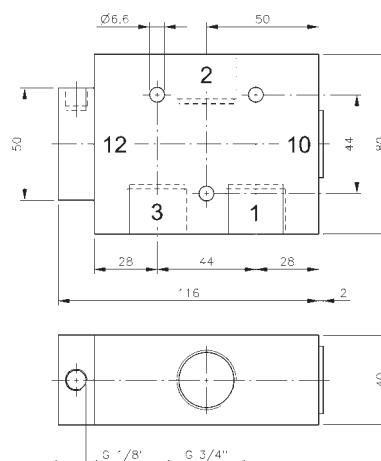

**P 310 181/P 311 181**

Type	Port size	Air flow	Operating press.	Actuating press.	Weight
P 310 101	G 3/8"	2250 l/min	1 - 10 bar	the same	0,32 kg
P 310 121	G 1/2"	3000 l/min	1 - 10 bar	the same	0,45 kg
P 310 181	G 3/4"	6000 l/min	1 - 10 bar	the same	0,85 kg
P 311 101	G 3/8"	2250 l/min	1 - 10 bar	3 - 10 bar	0,32 kg
P 311 121	G 1/2"	3000 l/min	1 - 10 bar	3 - 10 bar	0,45 kg
P 311 181	G 3/4"	6000 l/min	1 - 10 bar	3 - 10 bar	0,85 kg
P 310 121 NPT	1/2" NPT	3000 l/min	1 - 10 bar	the same	0,45 kg
P 311 121 NPT	1/2" NPT	3000 l/min	1 - 10 bar	3 - 10 bar	0,45 kg



P 310 701 G/P 311 701 G  
P 310 121 G/P 311 121 G

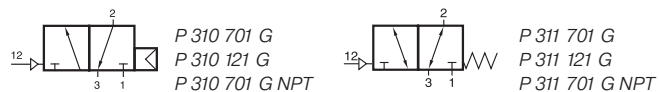

G-Series 701 G



G-Series 121 G

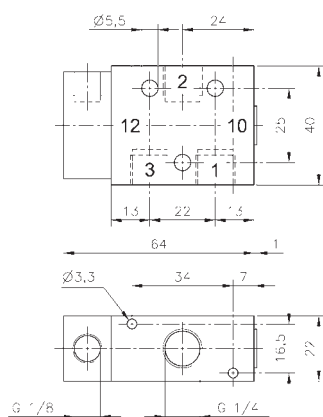
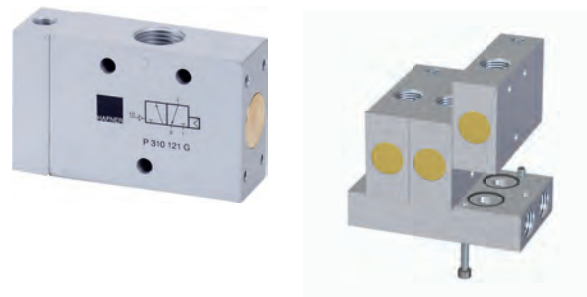

P 310 701 G/P 311 701 G  
P 310 701 G NPT/ P 311 701 G NPT

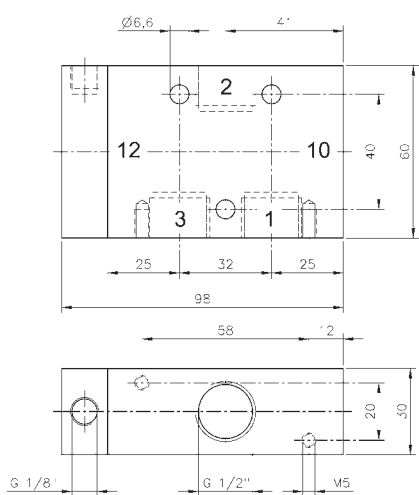

P 310 121 G/P 311 121 G

Pneumatically actuated 3/2-way spool valve.

Type P 310 \_\_\_ with air-spring-return.  
Operating pressure and actuating pressure should be at the same level.

Type P 311 \_\_\_ with mechanical spring return.

If pressure is attached to port 1 the function is normally closed.

If pressure is applied to port 3 the function is normally open.

Pressure can only be attached to port 2 if valve has a mechanical spring (type P 311\_\_\_).

If 2/2-way is required, please use type P 311 \_\_\_\_.  
Ports can be fully plugged.

The G-Series valves offer the flexibility of in-line fitment as well as the option of being assembled on to a manifold as shown. Plates are displayed on page 2.7.1.4 and 2.7.1.5.

Take into consideration that G 1/2" valves have to be assembled onto the plate by fixing screws from the bottom through the plate into the valve.

Exhaust can be throttled.

Type	Port size	Air flow	Operating press.	Actuating press.	Weight	
P 310 701 G	G 1/4"	1250 l/min	2 - 10 bar	the same	0,14 kg	❄
P 310 121 G	G 1/2"	3000 l/min	1 - 10 bar	the same	0,45 kg	
P 311 701 G	G 1/4"	1250 l/min	1 - 10 bar	3 - 10 bar	0,14 kg	❄
P 311 121 G	G 1/2"	3000 l/min	1 - 10 bar	3 - 10 bar	0,45 kg	
P 310 701 G NPT	1/4" NPT	1250 l/min	2 - 10 bar	the same	0,14 kg	
P 311 701 G NPT	1/4" NPT	1250 l/min	1 - 10 bar	3 - 10 bar	0,14 kg	

# P 320 302/P 320 502 P 322 302/P 322 502

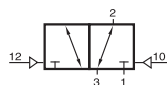

P 320 302  
P 320 502

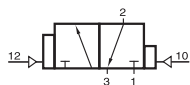

P 322 302  
P 322 502



Pneumatically actuated 3/2-way spool valve actuated by impulse.

Type P 320 \_\_\_ double pilot  
Type P 322 \_\_\_ double pilot dominating at port 12

If signal is applied to 12 the valve is open from 1 to 2 and 3 is blocked.

If signal is applied at 10 the valve is open from 2 to 3.

Position is kept until next pneumatic signal is applied.

Exhaust can be throttled.

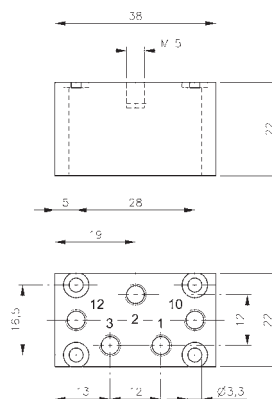

P 320 302/P 322 302

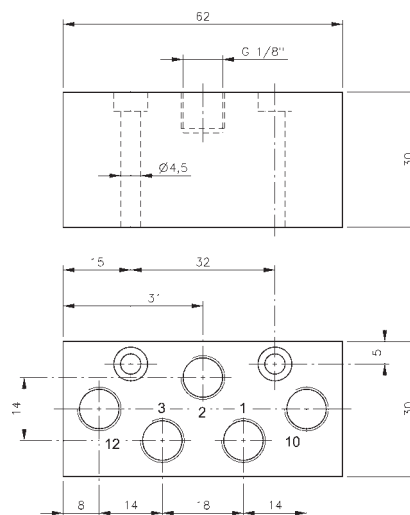

P 320 502/P 322 502

Type	Port size	Air flow	Operating press.	Actuating press.	Weight
P 320 302	M5	180 l/min	1 - 10 bar	2,5 - 10 bar	0,05 kg
P 320 502	G 1/8"	650 l/min	1 - 10 bar	2,5 - 10 bar	0,13 kg
P 322 302	M5	180 l/min	1 - 10 bar	2,5 - 10 bar	0,05 kg
P 322 502	G 1/8"	650 l/min	1 - 10 bar	2,5 - 10 bar	0,13 kg



P 320 501/P 320 701 G/ P 320 801  
P 322 501/P 322 701 G

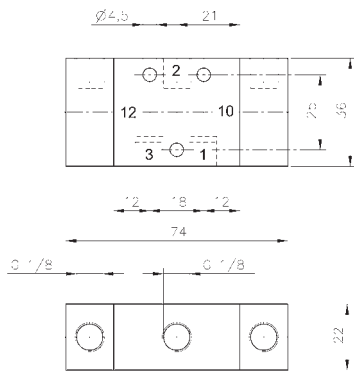
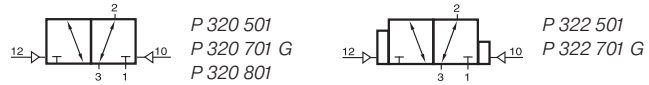

P 320 501/P 322 501

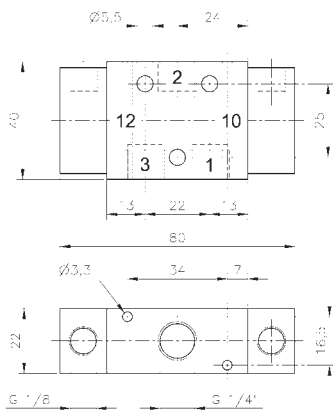

P 320 701 G/P 322 701 G

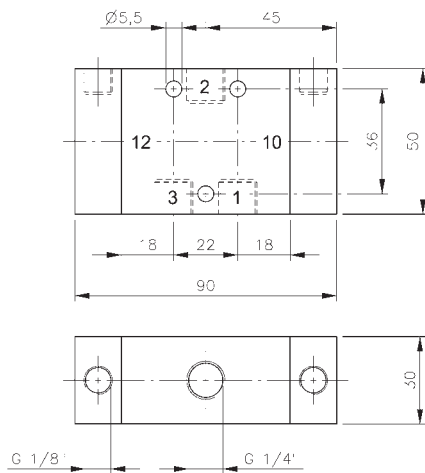

P 320 801

G-Series 701 G

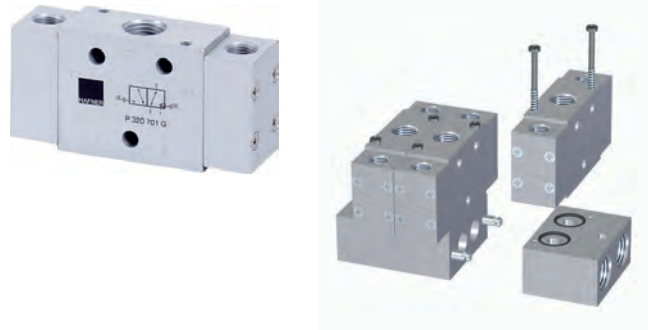

Pneumatically actuated 3/2-way spool valve actuated by impulse.

- Type P 320 \_\_\_ double pilot
  - Type P 322 \_\_\_ double pilot dominating at port 12
  - Type P 3\_\_ 701 G dual use, in-line and on manifold.
- Plates are displayed on page 2.7.1.4.

If signal is applied to 12 the valve is open from 1 to 2 and 3 is blocked.  
If signal is applied at 10 the valve is open from 2 to 3.

The G-Series valves offer the flexibility of in-line fitment as well as the option of being assembled on to a manifold as shown. Plates are displayed on page 2.7.1.4 and 2.7.1.5.

Position is kept until next pneumatic signal is applied.

Operating pressure can also be applied to 2.

Exhaust can be throttled.

Type	Port size	Air flow	Operating press.	Actuating press.	Weight	
P 320 501	G 1/8"	650 l/min	1 - 10 bar	2,5 - 10 bar	0,16 kg	Ex ❄️
P 322 501	G 1/8"	650 l/min	1 - 10 bar	2,5 - 10 bar	0,16 kg	
P 320 701 G	G 1/4"	1250 l/min	1 - 10 bar	2,5 - 10 bar	0,17 kg	Ex ❄️
P 322 701 G	G 1/4"	1250 l/min	1 - 10 bar	2,5 - 10 bar	0,17 kg	
P 320 801	G 1/4"	1450 l/min	1 - 10 bar	2,5 - 10 bar	0,34 kg	Ex



# P 320 101/P 320 121/P 320 181

2.4.1.7  
page 56

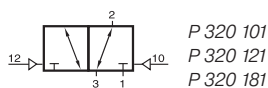

Pneumatically actuated 3/2-way spool valve actuated by impulse.

If signal is applied to 12 the valve is open from 1 to 2 and 3 is blocked.

If signal is applied at 10 the valve is open from 2 to 3.

Operating pressure can also be applied to 2.

Position is kept until next pneumatic signal is applied.

Exhaust can be throttled.

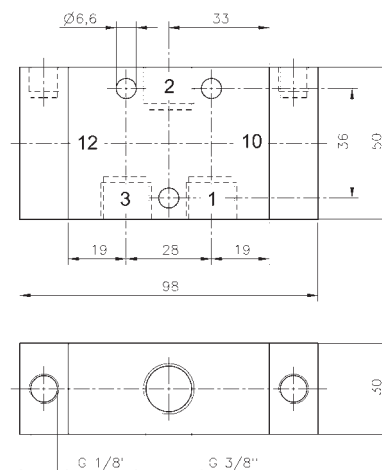

**P 320 101**

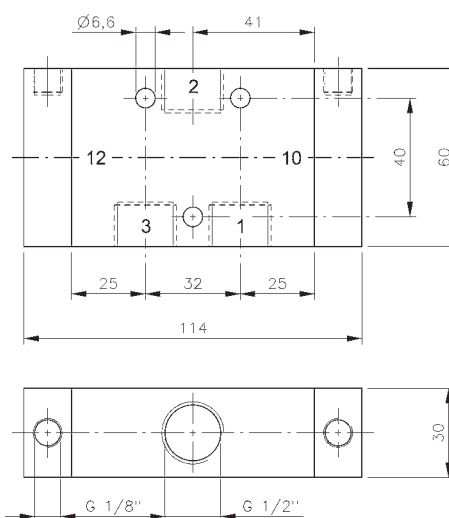

**P 320 121**

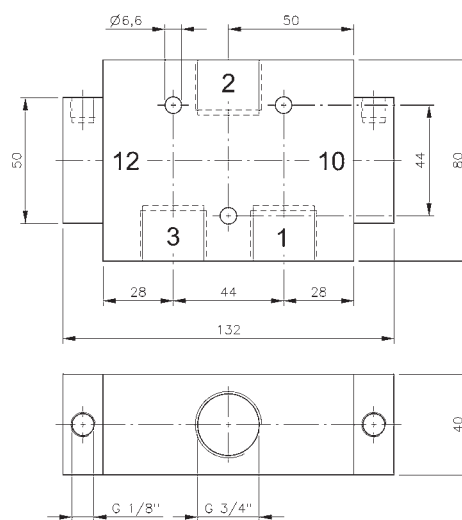

**P 320 181**

Type	Port size	Air flow	Operating press.	Actuating press.	Weight	
P 320 101	G 3/8"	2250 l/min	1 - 10 bar	2,5 - 10 bar	0,38 kg	Ex
P 320 121	G 1/2"	3000 l/min	1 - 10 bar	2,5 - 10 bar	0,52 kg	Ex
P 320 181	G 3/4"	6000 l/min	1 - 10 bar	2 - 10 bar	0,88 kg	





P 510 302/P 510 502

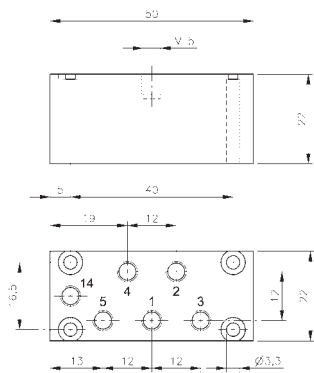
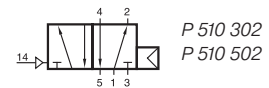

**P 510 302**

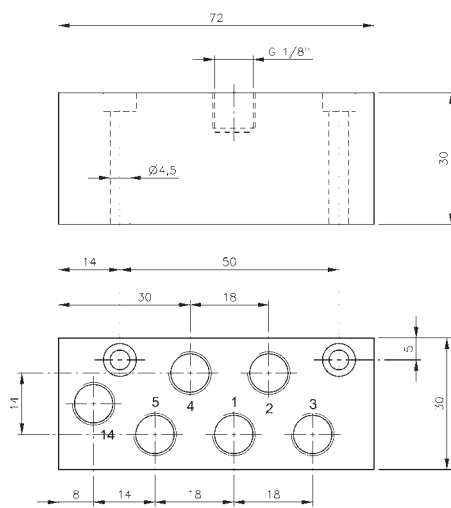

**P 510 502**



Pneumatically actuated 5/2-way spool valve actuated by permanent signal and equipped with air spring return.

Normally open from 1 to 2 and from 4 to 5. If pressure is applied at 14 the valve is open from 1 to 4 and 2 to 3.

Operating pressure and actuating pressure should be at the same level.

Exhaust can be throttled.

Type	Port size	Air flow	Operating press.	Actuating press.	Weight
P 510 302	M5	180 l/min	2 - 10 bar	the same	0,07 kg
P 510 502	G 1/8"	650 l/min	2 - 10 bar	the same	0,17 kg



# P 510 501/P 510 701/P 510 801 P 511 501/P 511 701/P 511 801

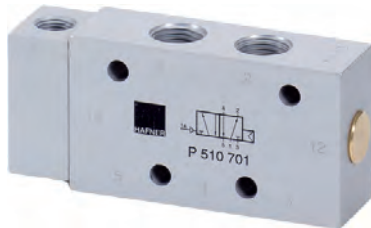
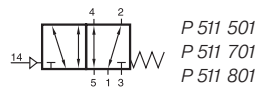
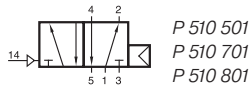

Pneumatically actuated 5/2-way spool valve.

Type P 510 \_\_\_ with air-spring-return.  
Operating pressure and actuating pressure should be at the same level.

Type P 511 \_\_\_ with mechanical spring return.

Normally open from 1 to 2 and from 4 to 5.  
If pressure is applied at 14 the valve is open from 1 to 4 and 2 to 3.

Exhaust can be throttled.

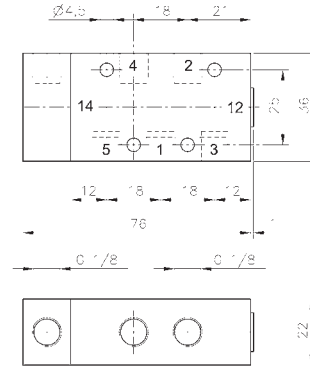

P 510 501/P 511 501

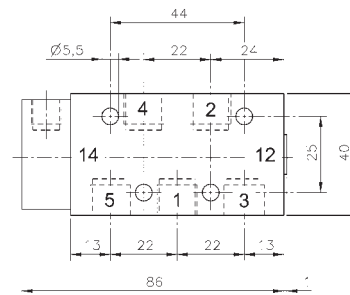

P 510 701/P 511 701

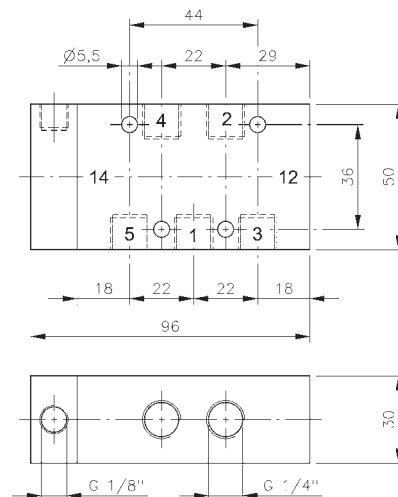

P 510 801/P 511 801

Type	Port size	Air flow	Operating press.	Actuating press.	Weight	
P 510 501	G 1/8"	650 l/min	2 - 10 bar	the same	0,16 kg	Ex
P 510 701	G 1/4"	1250 l/min	2 - 10 bar	the same	0,18 kg	Ex 316
P 510 801	G 1/4"	1450 l/min	1,5 - 10 bar	the same	0,38 kg	Ex
P 511 501	G 1/8"	650 l/min	1 - 10 bar	3 - 10 bar	0,16 kg	
P 511 701	G 1/4"	1250 l/min	1 - 10 bar	3 - 10 bar	0,18 kg	316
P 511 801	G 1/4"	1450 l/min	1 - 10 bar	3 - 10 bar	0,38 kg	



P 510 101/P 510 121/P 510 181  
P 511 101/P 511 121/P 511 181

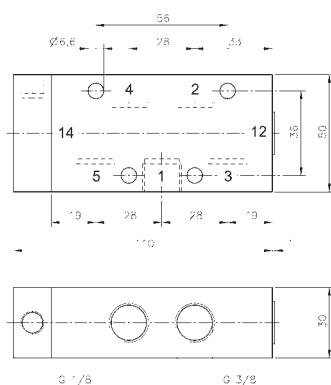

P 510 101/P 511 101

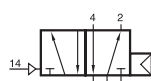

P 510 101  
P 510 121  
P 510 181  
P 510 121 NPT

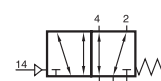

P 511 101  
P 511 121  
P 511 181  
P 511 121 NPT

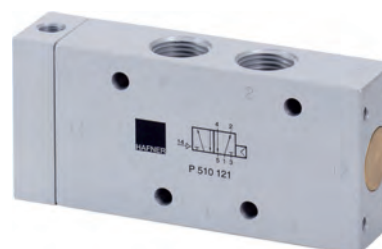

Pneumatically actuated 5/2-way spool valve.

Type P 510 \_\_\_ with air-spring-return.  
Operating pressure and actuating pressure should be at the same level.

Type P 511 \_\_\_ with mechanical spring return.

Normally open from 1 to 2 and from 4 to 5.  
If pressure is applied at 14 the valve is open from 1 to 4 and 2 to 3.

Exhaust can be throttled.

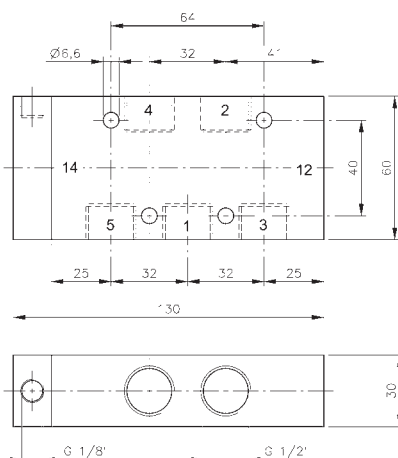

P 510 121/P 511 121  
P 510 121 NPT/P511 121 NPT

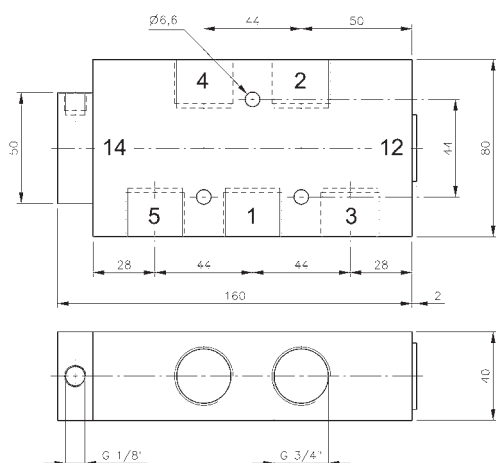

P 510 181/P 511 181

Type	Port size	Air flow	Operating press.	Actuating press.	Weight
P 510 101	G 3/8"	2250 l/min	1,5 - 10 bar	the same	0,42 kg
P 510 121	G 1/2"	3000 l/min	1 - 10 bar	the same	0,59 kg
P 510 181	G 3/4"	6000 l/min	1 - 10 bar	the same	1,18 kg
P 511 101	G 3/8"	2250 l/min	1 - 10 bar	3 - 10 bar	0,42 kg
P 511 121	G 1/2"	3000 l/min	1 - 10 bar	3 - 10 bar	0,59 kg
P 511 181	G 3/4"	6000 l/min	1 - 10 bar	3 - 10 bar	1,18 kg
P 510 121 NPT	1/2" NPT	3000 l/min	1 - 10 bar	the same	0,59 kg
P 511 121 NPT	1/2" NPT	3000 l/min	1 - 10 bar	3 - 10 bar	0,59 kg



**P 510 501 G/P 510 701 G/P 510 121 G**  
**P 511 501 G/P 511 701 G/P 511 121 G**

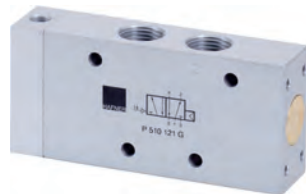
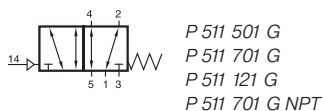
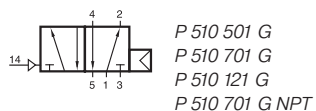

G-Series 501 G/701 G

G-Series 121 G



Pneumatically actuated 5/2-way spool valve.

Type P 510 \_\_\_ with air-spring-return.  
Operating pressure and actuating pressure should be at the same level.

Type P 511 \_\_\_ with mechanical spring return.

Normally open from 1 to 2 and from 4 to 5.  
If pressure is applied at 14 the valve is open from 1 to 4 and 2 to 3.

The G-Series valves offer the flexibility of in-line fitment as well as the option of being assembled on to a manifold as shown. Manifolds for valves type 501 G are displayed on page 2.7.2.2, manifolds for valves type 701 G are displayed on page 2.7.2.3, manifolds for valves type 121 G are displayed on page 2.7.2.5.

Take into consideration, that G 1/2" valves have to be assembled onto the plate by fixing screws from the bottom through the plate into the valve.

Exhaust can be throttled.

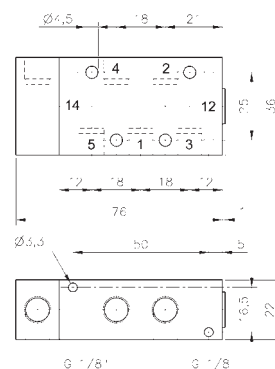

**P 510 501 G/P 511 501 G**

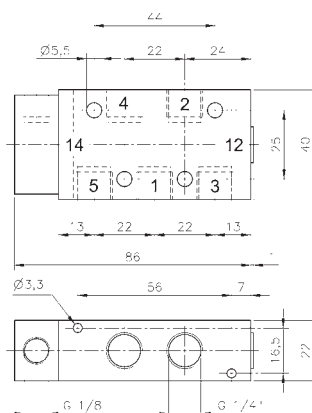

**P 510 701 G/P 511 701 G**  
**P 501 701 G NPT/P 511 701 G NPT**

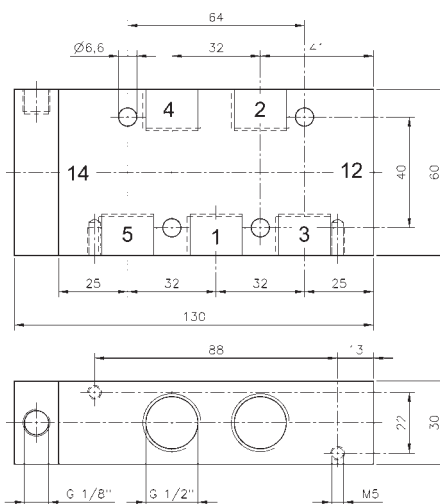

**P 510 121 G/P 511 121 G**

Type	Port size	Air flow	Operating press.	Actuating press.	Weight
P 510 501 G	G 1/8"	650 l/min	2 - 10 bar	the same	0,16 kg ❄
P 510 701 G	G 1/4"	1250 l/min	2 - 10 bar	the same	0,18 kg ❄
P 510 121 G	G 1/2"	3000 l/min	1 - 10 bar	the same	0,59 kg
P 511 501 G	G 1/8"	650 l/min	1 - 10 bar	3 - 10 bar	0,16 kg ❄
P 511 701 G	G 1/4"	1250 l/min	1 - 10 bar	3 - 10 bar	0,18 kg ❄
P 511 121 G	G 1/2"	3000 l/min	1 - 10 bar	3 - 10 bar	0,59 kg
P 510 701 G NPT	1/4" NPT	1250 l/min	2 - 10 bar	the same	0,18 kg
P 511 701 G NPT	1/4" NPT	1250 l/min	1 - 10 bar	3 - 10 bar	0,18 kg

# P 520 302/P 520 502

2.4.2.5  
page 61

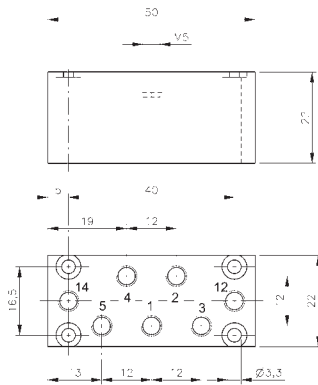
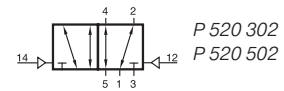

**P 520 302**

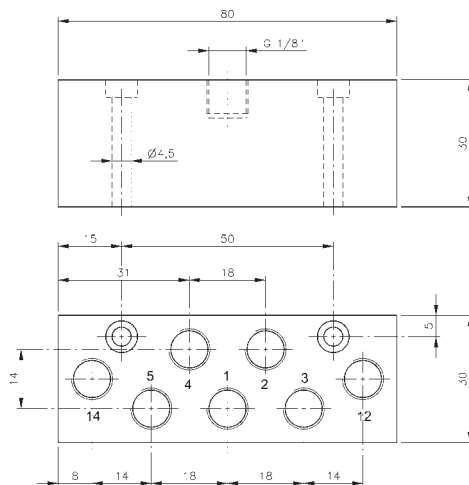

**P 520 502**



Pneumatically actuated 5/2-way spool valve actuated by impulse.

If signal is applied to 14 the valve is open from 1 to 4 and 2 to 3, 5 is closed.

If signal is applied to 12 the valve is open from 1 to 2 and 4 to 5.

Position is kept until next pneumatic signal is applied.

Exhaust can be throttled.

5/3-way centre closed version type P 531 302 available on request.

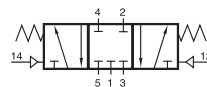

Type	Port size	Air flow	Operating press.	Actuating press.	Weight
P 520 302	M5	180 l/min	1 - 10 bar	2,5 - 10 bar	0,07 kg
P 520 502	G 1/8"	650 l/min	1 - 10 bar	2,5 - 10 bar	0,17 kg



HAFNER

# P 520 501/P 520 701/P 520 801 P 522 501/P 522 701

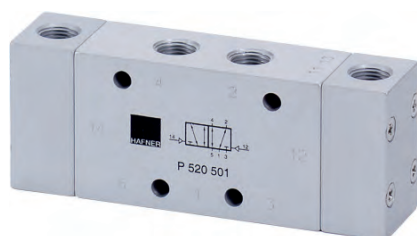
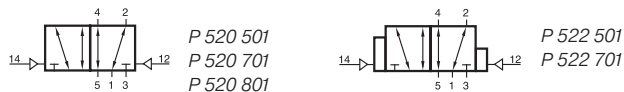

Pneumatically actuated 5/2-way spool valve.

Type P 520 \_\_\_ double pilot

Type P 522 \_\_\_ double pilot dominating at port 14

If signal is applied to 14 the valve is open from 1 to 4 and 2 to 3, 5 is closed.

If signal is applied to 12 the valve is open from 1 to 2 and 4 to 5.

Position is kept until next pneumatic signal is applied.

Exhaust can be throttled.

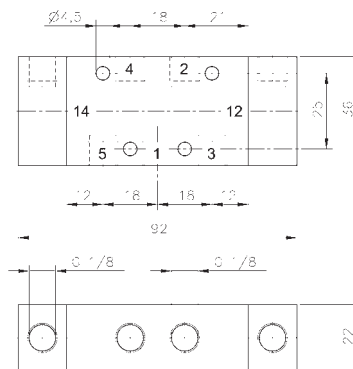

P 520 501/P 522 501

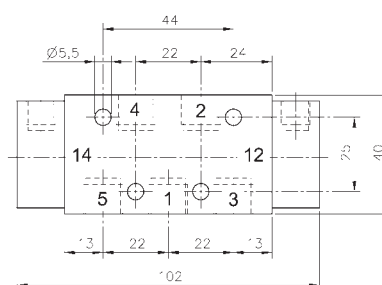

P 520 701/P 522 701

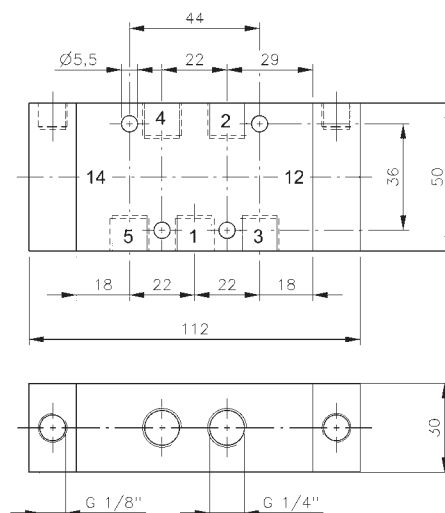

P 520 801

Type	Port size	Air flow	Operating press.	Actuating press.	Weight
P 520 501	G 1/8"	650 l/min	1 - 10 bar	2,5 - 10 bar	0,20 kg
P 522 501	G 1/8"	650 l/min	1 - 10 bar	2,5 - 10 bar	0,20 kg
P 520 701	G 1/4"	1250 l/min	1 - 10 bar	2,5 - 10 bar	0,22 kg
P 522 701	G 1/4"	1250 l/min	1 - 10 bar	2,5 - 10 bar	0,22 kg
P 520 801	G 1/4"	1450 l/min	1 - 10 bar	2,5 - 10 bar	0,44 kg



# P 520 101/P 520 121/P 520 181

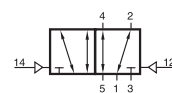

P 520 101  
P 520 121  
P 520 181  
P 520 121 NPT

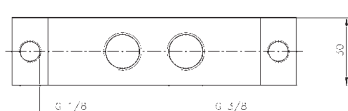
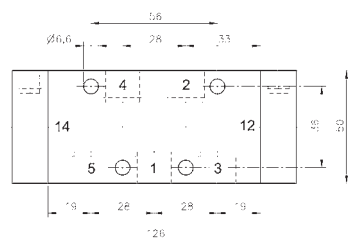

**P 520 101**

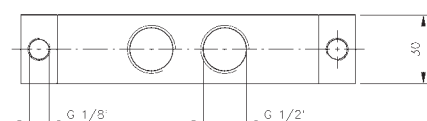
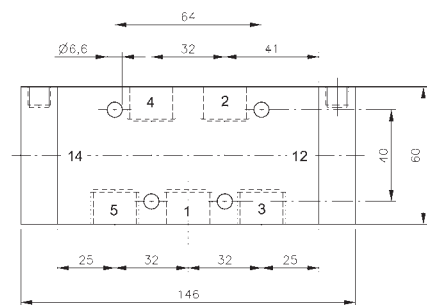

**P 520 121/P 520 121 NPT**

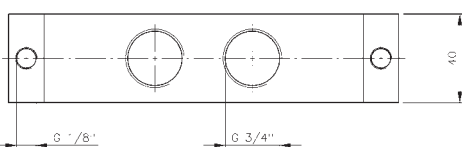
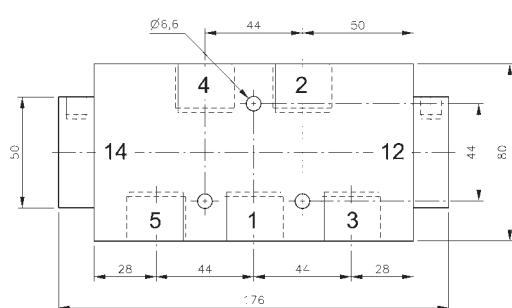

**P 520 181**

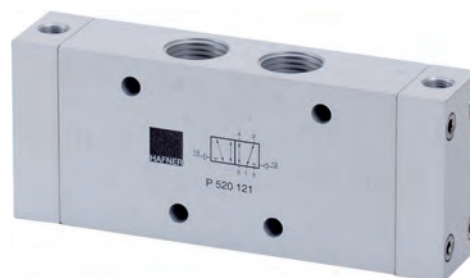

Pneumatically actuated 5/2-way spool valve actuated by impulse.

If signal is applied to 14 the valve is open from 1 to 4 and 2 to 3, 5 is closed.

If signal is applied to 12 the valve is open from 1 to 2 and 4 to 5.

Position is kept until next pneumatic signal is applied.

Exhaust can be throttled.

Type	Port size	Air flow	Operating press.	Actuating press.	Weight
P 520 101	G 3/8"	2250 l/min	1 - 10 bar	2,5 - 10 bar	0,48 kg
P 520 121	G 1/2"	3000 l/min	1 - 10 bar	2,5 - 10 bar	0,67 kg
P 520 181	G 3/4"	6000 l/min	1 - 10 bar	2 - 10 bar	1,22 kg
P 520 121 NPT	1/2" NPT	3000 l/min	1 - 10 bar	2,5 - 10 bar	0,67 kg



# P 520 501 G/P 520 701 G/P 520 121 G P 522 501 G/P 522 701 G

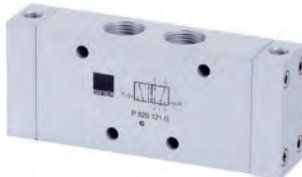
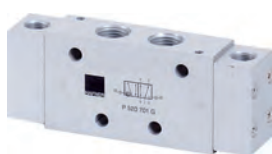
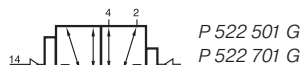
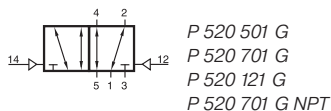

G-Series 501 G/701 G

G-Series 121 G



Pneumatically actuated 5/2-way spool valve.

Type P 520 \_\_\_ double pilot

Type P 522 \_\_\_ double pilot dominating at port 14

If signal is applied to 14 the valve is open from 1 to 4 and 2 to 3, 5 is closed.

If signal is applied to 12 the valve is open from 1 to 2 and 4 to 5.

Position is kept until next pneumatic signal is applied.

The G-Series valves offer the flexibility of in-line fitment as well as the option of being assembled on to a manifold as shown. Manifolds for valves type 501 G are displayed on page 2.7.2.2, manifolds for valves type 701 G are displayed on page 2.7.2.3, manifolds for valves type 121 G are displayed on page 2.7.2.5.

Take into consideration, that G 1/2" valves have to be assembled onto the plate by fixing screws from the bottom through the plate into the valve.

Exhaust can be throttled.

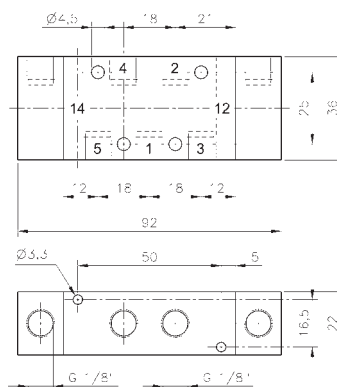

P 520 501 G/P 522 501 G

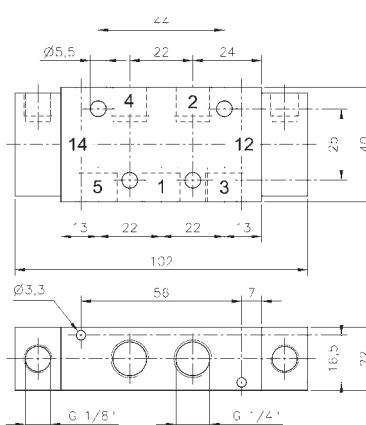

P 520 701 G/P 522 701 G  
P 520 701 G NPT

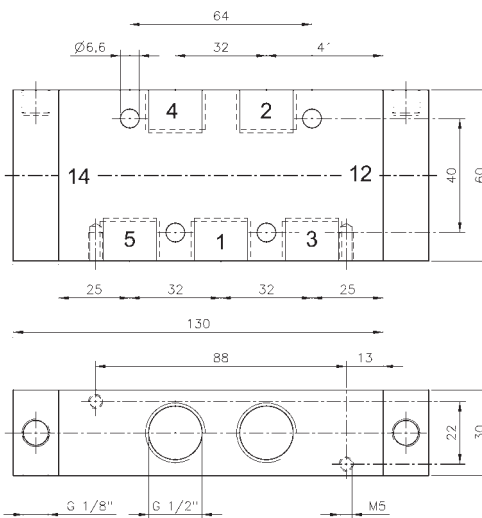

P 520 121 G

Type	Port size	Air flow	Operating press.	Actuating press.	Weight
P 520 501 G	G 1/8"	650 l/min	1 - 10 bar	2,5 - 10 bar	0,20 kg ❄️
P 522 501 G	G 1/8"	650 l/min	1 - 10 bar	2,5 - 10 bar	0,20 kg
P 520 701 G	G 1/4"	1250 l/min	1 - 10 bar	2,5 - 10 bar	0,22 kg ❄️
P 522 701 G	G 1/4"	1250 l/min	1 - 10 bar	2,5 - 10 bar	0,22 kg
P 520 121 G	G 1/2"	3000 l/min	1 - 10 bar	2,5 - 10 bar	0,67 kg
P 520 701 G NPT	1/4" NPT	1250 l/min	1 - 10 bar	2,5 - 10 bar	0,22 kg





P 53\_ 501/P 53\_ 701/P 53\_ 801

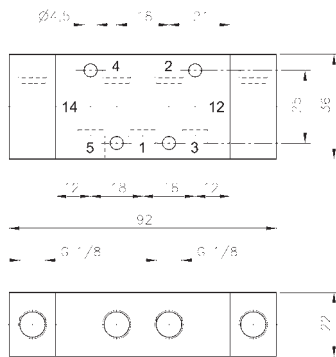
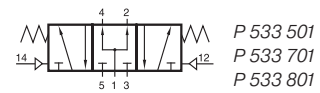
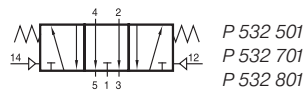
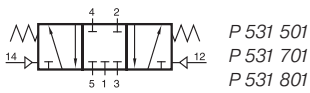

P 53\_ 501

Pneumatically actuated 5/3-way spool valve with spring return to middle position.

- Type 531 centre closed
- Type 532 centre exhausted
- Type 533 centre pressurised

When ordering please complete the type number by 1, 2 or 3 according to the type required.

Exhaust can be throttled.

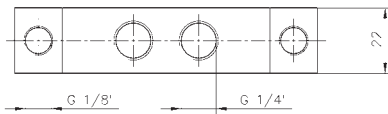
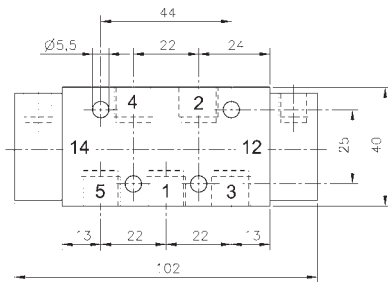

P 53\_ 701

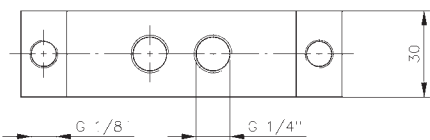
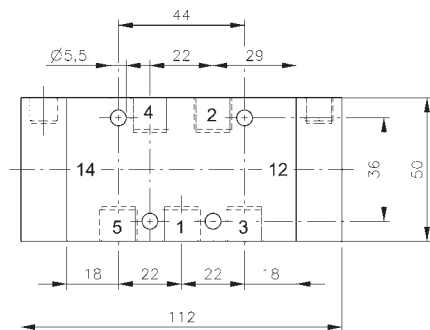

P 53\_ 801

Type	Port size	Air flow	Operating press.	Actuating press.	Weight
P 53_ 501	G 1/8"	650 l/min	1 - 10 bar	3 - 10 bar	0,20 kg
P 53_ 701	G 1/4"	1250 l/min	1 - 10 bar	3 - 10 bar	0,22 kg
P 53_ 801	G 1/4"	1450 l/min	1 - 10 bar	3 - 10 bar	0,44 kg



# P 53\_ 101/P 53\_ 121/P 53\_ 181

2.4.3.2  
page 66

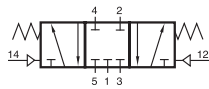

P 531 101  
P 531 121  
P 531 181  
P 531 121 NPT

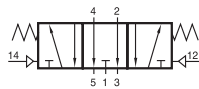

P 532 101  
P 532 121  
P 532 181  
P 532 121 NPT

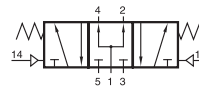

P 533 101  
P 533 121  
P 533 181  
P 533 121 NPT

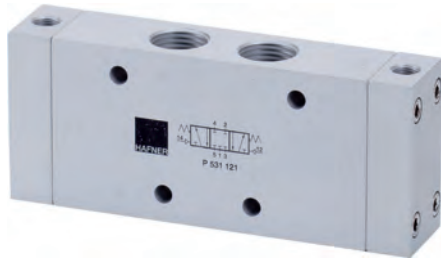

Pneumatically actuated 5/3-way spool valve with spring return to middle position.

- Type 531 centre closed
- Type 532 centre exhausted
- Type 533 centre pressurised

When ordering please complete the type number by 1, 2 or 3 according to the type required.

Exhaust can be throttled.

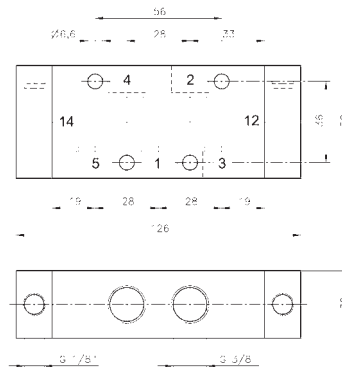

P 53\_ 101

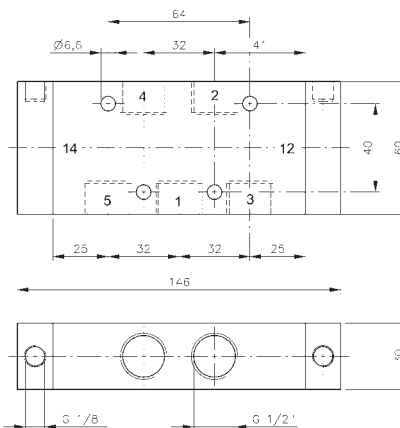

P 53\_ 121/P 53\_ 121 NPT

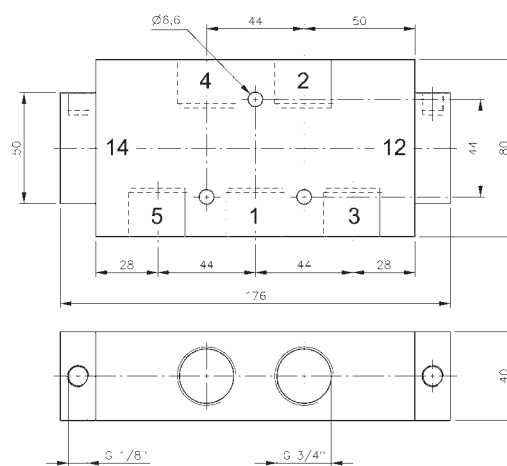

P 53\_ 181

Type	Port size	Air flow	Operating press.	Actuating press.	Weight
P 53_ 101	G 3/8"	2250 l/min	1 - 10 bar	3 - 10 bar	0,49 kg
P 53_ 121	G 1/2"	3000 l/min	1 - 10 bar	3 - 10 bar	0,69 kg
P 53_ 181	G 3/4"	6000 l/min	1 - 10 bar	3 - 10 bar	1,22 kg
P 53_ 121 NPT	1/2" NPT	3000 l/min	1 - 10 bar	3 - 10 bar	0,69 kg



P 53\_ 501 G/P 53\_ 701 G/P 53\_ 121 G

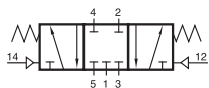

P 531 501 G  
P 531 701 G  
P 531 121 G  
P 531 701 G NPT

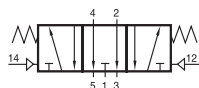

P 532 501 G  
P 532 701 G  
P 532 121 G  
P 532 701 G NPT

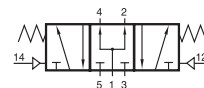

P 533 501 G  
P 533 701 G  
P 533 121 G  
P 533 701 G NPT

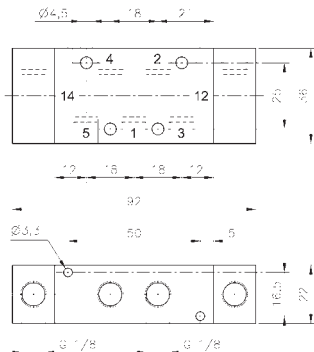

P 53\_ 501 G



G-Series 501 G/701 G



G-Series 121 G

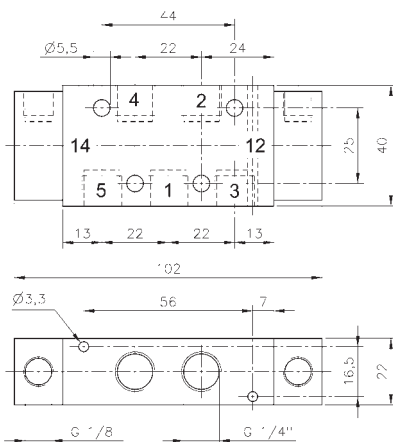

P 53\_ 701 G/P 53\_ 701 G NPT

Pneumatically actuated 5/3-way spool valve with spring return to middle position.

- Type 531 centre closed
- Type 532 centre exhausted
- Type 533 centre pressurised

When ordering please complete the type number by 1, 2 or 3 according to the type in need.

The G-Series valves offer the flexibility of in-line fitment as well as the option of being assembled onto a manifold as shown. Manifolds for valves type 501 G are displayed on page 2.7.2.2, manifolds for valves type 701 G are displayed on page 2.7.2.3, manifolds for valves type 121 G are displayed on page 2.7.2.5.

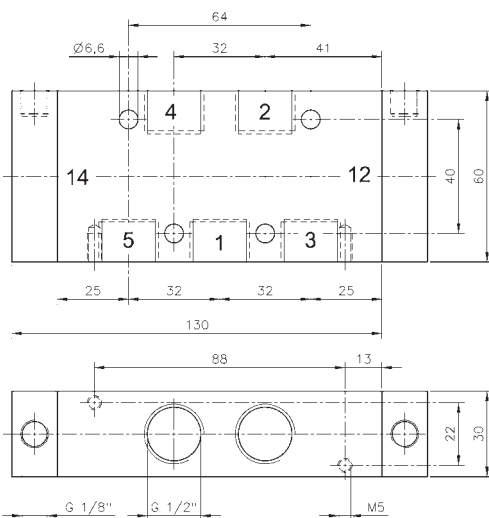

P 53\_ 121 G

Take into consideration, that G 1/2" valves have to be assembled onto the plate by fixing screws from the bottom through the plate into the valve.

Exhaust can be throttled.

Type	Port size	Air flow	Operating press.	Actuating press.	Weight
P 53_ 501 G	G 1/8"	650 l/min	1 - 10 bar	3 - 10 bar	0,20 kg ❄️
P 53_ 701 G	G 1/4"	1250 l/min	1 - 10 bar	3 - 10 bar	0,22 kg ❄️
P 53_ 121 G	G 1/2"	3000 l/min	1 - 10 bar	3 - 10 bar	0,69 kg
P 53_ 701 G NPT	1/4" NPT	1250 l/min	1 - 10 bar	3 - 10 bar	0,22 kg



# P 510 704/P 520 704/P 53\_704

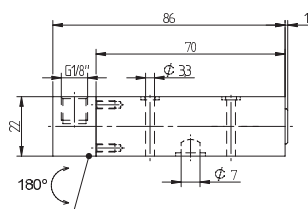
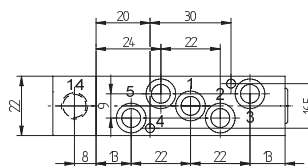
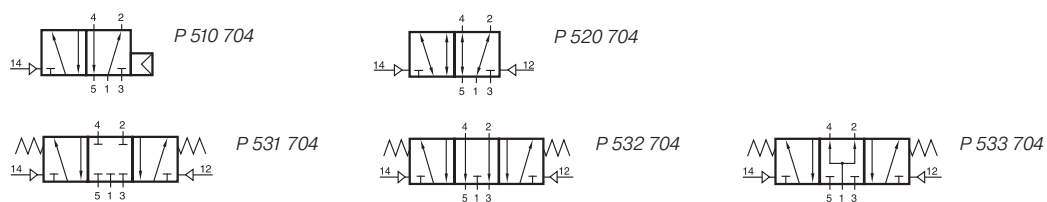

**P 510 704**

Pneumatically actuated 5/2-way and 5/3-way spool valves. All the ports are in the plate.

Type 510	single pilot	5/2-way
Type 520	double pilot	5/2-way
Type 531	centre closed	5/3-way
Type 532	centre exhausted	5/3-way
Type 533	centre pressurized	5/3-way

Manifolds are displayed on page 2.7.2.8.

Blanking plates are also available type BP 5 704.

Mounting screws and seals are included.

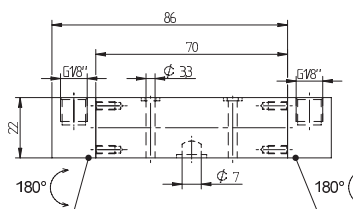
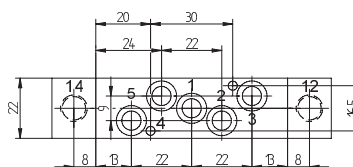

**P 520 704/P 53\_704**

Type	Function	Port size	Air flow	Operating press.	Actuating press.	Weight
P 510 704	5/2-way single pilot	Ø 7 mm	1250 l/min	2 - 10 bar	the same	0,20 kg
P 520 704	5/2-way double pilot	Ø 7 mm	1250 l/min	1 - 10 bar	2,5 - 10 bar	0,29 kg
P 53_704	5/3-way	Ø 7 mm	1250 l/min	1 - 10 bar	3 - 10 bar	0,29 kg

# VA 341/VA 361/VA 401 ES 341/ES 401

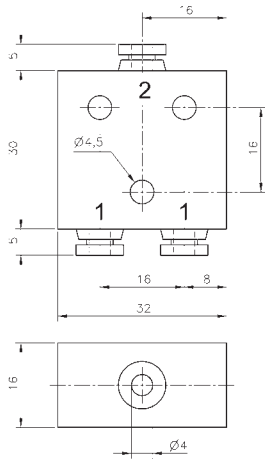

VA 341/ES 341

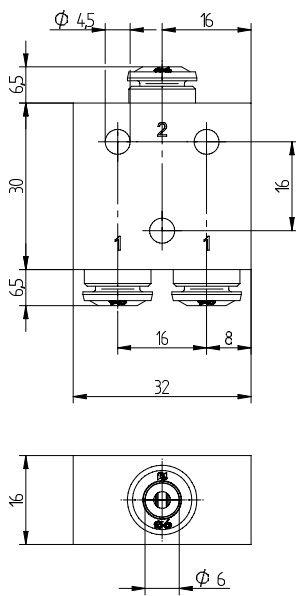

VA 361

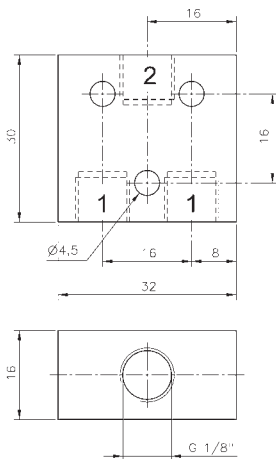

VA 401/ES 401

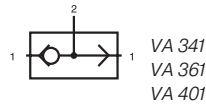

VA 341  
VA 361  
VA 401

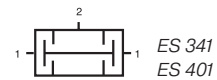

ES 341  
ES 401



### VA 341/VA 361/VA 401: OR-gate

The OR-gate has two inputs 1 and one output 2.

The shuttle valve is used when only one of two possible signals is required to pass on a signal.

Function: If one of two signal inputs are activated, an output signal on port 2 is present and the other input is blocked.

In case of pressurising both inputs at different pressure levels, the higher pressure is fed to port 2.

### ES 341/ES 401: AND-gate

The AND-gate has two inputs 1 and one output 2.

The dual-pressure valve is used when at least 2 signals are required before a signal is passed on.

Function: Only when both inputs are pressurised output 2 is pressurised.

If two different pressures are applied the lower pressure is fed to output 2.

In case of only one signal at one of the two ports 1, the output 2 is blocked.

Type	Function	Port size	Air flow	Operating press.	Weight
VA 341	OR	pif 4 mm	280 l/min	1 - 10 bar	0,04 kg
VA 361	OR	pif 6 mm	280 l/min	1 - 10 bar	0,04 kg
VA 401	OR	G 1/8"	280 l/min	1 - 10 bar	0,04 kg ❄️
ES 341	AND	pif 4 mm	280 l/min	1 - 10 bar	0,04 kg
ES 401	AND	G 1/8"	280 l/min	1 - 10 bar	0,04 kg ❄️



# SE 501/SE 801/SE 8101/SE 121

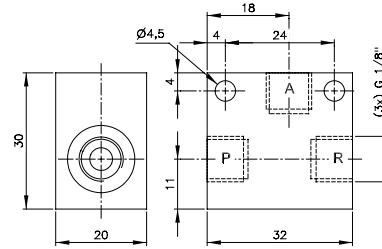
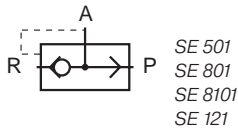

SE 501

Quick-exhaust valve which can also be used as non-return valve as well as or-gate.

If used as a non-return valve please plug port R. Open from P to A, closed from A to P.

If used as an or-gate connect pressure to P and R. Port A is outlet.

Temperature range: -20° C to +80° C

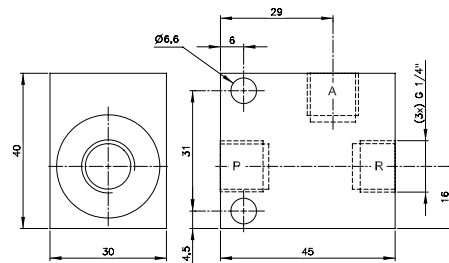

SE 801

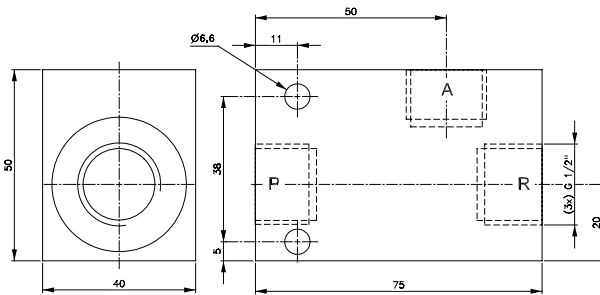

SE 121

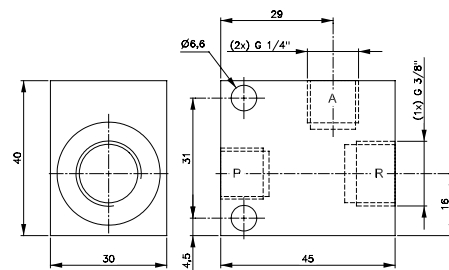

SE 8101

Type	Port size A + P	Port size R	Air flow from A to R	Operating press.	Weight
SE 501	G 1/8"	G 1/8"	564 l/min	0,3 - 10 bar	0,06 kg
SE 801	G 1/4"	G 1/4"	1188 l/min	0,2 - 10 bar	0,18 kg
SE 8101	G 1/4"	G 3/8"	1188 l/min	0,2 - 10 bar	0,18 kg
SE 121	G 1/2"	G 1/2"	3600 l/min	0,5 - 10 bar	0,26 kg



P 311 501 SR/P 411 701 SR  
P 411 701 SR NPT

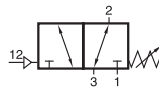

P 311 501 SR

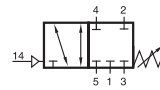

P 411 701 SR  
P 411 701 SR NPT

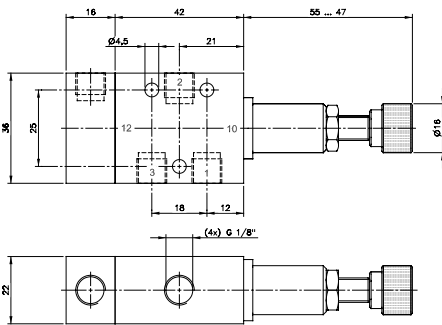

P 311 501 SR

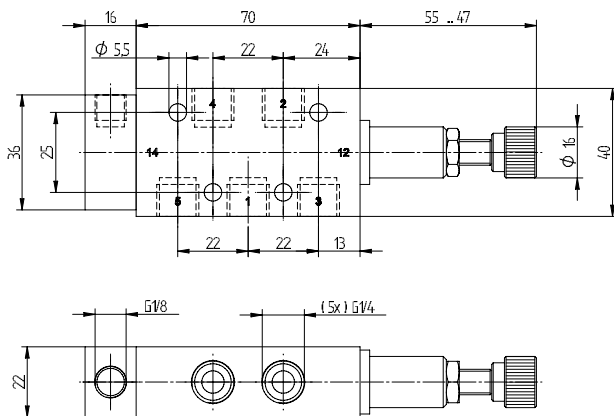

P 411 701 SR/P 411 701 SR NPT



**P 311 501 SR** pneumatically actuated 3/2-way valve with mechanical spring return. Valve can be used normally closed (pressure at port 1) and normally open (pressure at port 3). Can also be used as 2/2-way valve. Unused port to be closed with a silencer or plug.

**P 411 701 SR** pneumatically actuated 4/2-way valve with mechanical spring return. Valve either blocks all ports or is open from 1 to 4 and from 3 to 2. Port 5 is a vent port and should have a silencer installed, do not plug.

Valve can be used as an **adjustable pneumatic pressure switch**. By turning the hand-wheel the required minimum actuation pressure can be set. Adjustment is not independent from operation pressure. Switch-on pressure differs from switch-off pressure due to a hysteresis of around 1.5 bar. The hysteresis is the difference between the pressure point when the valve is opening (e.g. 5 bar) and closing (e.g. 3.5). The 1.5 bar hysteresis is just a reference point as it is depending on the friction force. The proportion between the friction force and the force of the air is changing when the air pressure increases. Therefore the hysteresis is getting smaller when the set actuating pressure increases.

Type	Port size	Air flow	Operating press.	Regulating range act. press.	Max. act. press.	Weight
P 311 501 SR	G 1/8"	650 l/min	2 - 10 bar	3 - 6 bar	10 bar	0,16 kg
P 311 501 SR 02	G 1/8"	650 l/min	2 - 10 bar	5 - 8 bar	10 bar	0,16 kg
P 311 501 SR 03	G 1/8"	650 l/min	2 - 10 bar	2 - 4 bar	10 bar	0,16 kg
P 411 701 SR	G 1/4"	1250 l/min	2 - 10 bar	3 - 6 bar	10 bar	0,21 kg
P 411 701 SR NPT	1/4" NPT	1250 l/min	2 - 10 bar	3 - 6 bar	10 bar	0,21 kg



# ERV 701/ERV 101/ERV 121

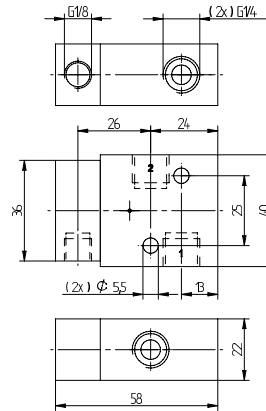
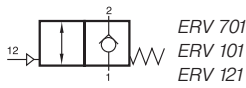

ERV 701

Pilot operated non-return valve.

Port 1 is blocked in basic position, but port 2 can exhaust through port 1.

When a pilot signal is applied to port 12, the valve opens from 1 to 2.

Valve can be used to lock the air in a cylinder in case of loss of air pressure.

Cylinder in movement:

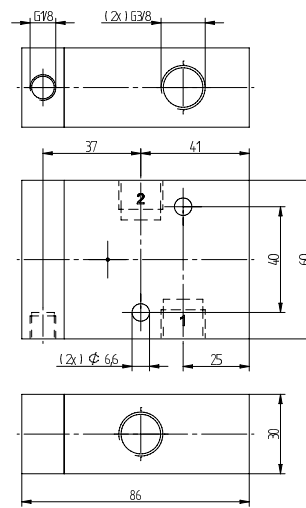
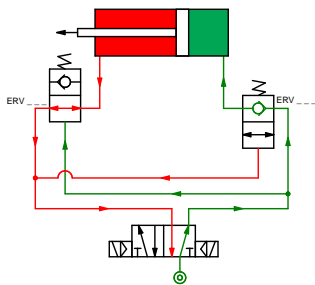

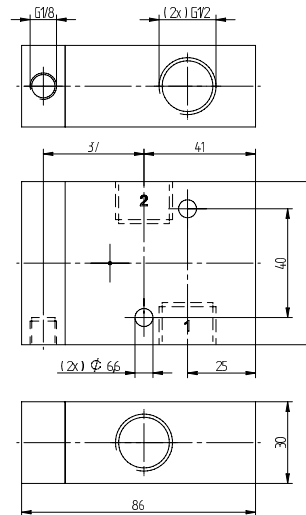
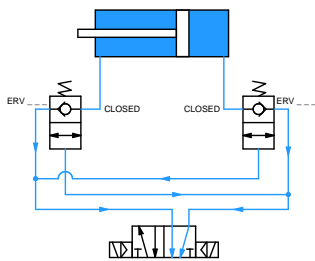

ERV 101

Pressure loss:



ERV 121

Type	Port size 1 and 2	Port size 12	Air flow	Operating press.	Weight
ERV 701	G 1/4"	G 1/8"	1250 l/min	1 - 10 bar	0,14 kg 
ERV 101	G 3/8"	G 1/8"	2250 l/min	1 - 10 bar	0,32 kg 
ERV 121	G 1/2"	G 1/8"	3000 l/min	1 - 10 bar	0,45 kg 



# DSV-1/8 / DSV-1/4 DSVH-1/8 / DSVH-1/4

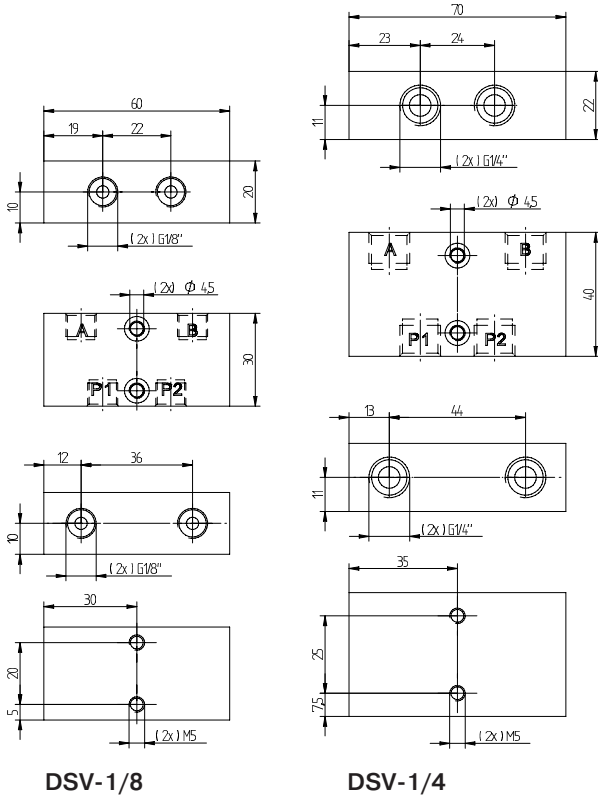

DSV-1/8

DSV-1/4

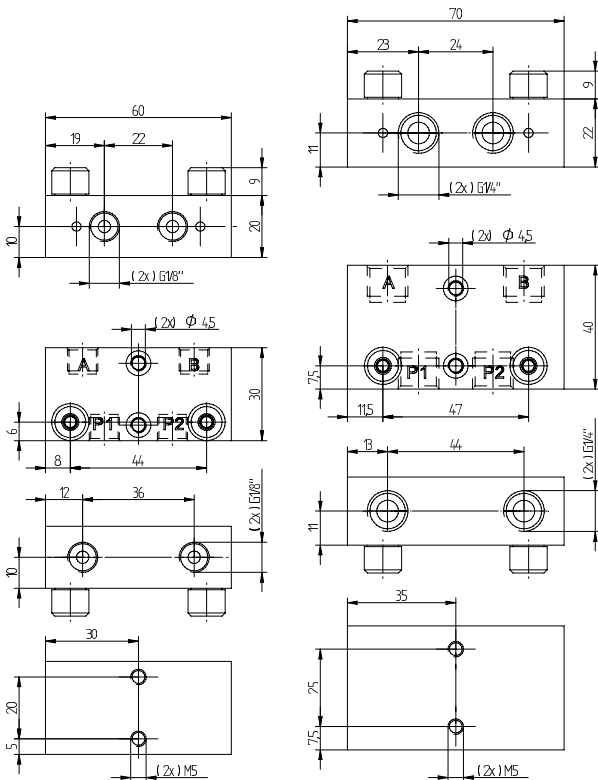

DSVH-1/8

DSVH-1/4

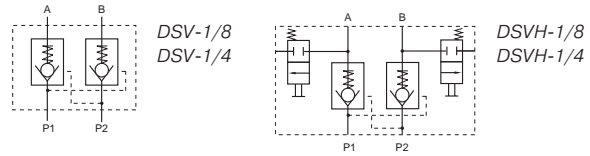

Pressure holding valves to hold a double acting actuator at the current position in case of pressure failure.

The valve consists of two non-return valves which will be unlocked by pressurising port P1 or P2.

Installation between pilot valve and actuator.

This valve is often used for gripper-applications. In case of pressure failure, the Hafner valve is locking the air in the gripper and thereby it does not lose its load.

Type DSVH with manual exhaust function. The user can exhaust the actuator manually by pushing the manual exhaust buttons.

Inner parts are made of brass and POM, seals are made of NBR.

Type	Port size	Air flow P to A/B	Air flow A/B to P	Operating press.	Weight
DSV-1/8	G 1/8"	230 l/min	360 l/min	1 - 10 bar	0,10 kg
DSV-1/4	G 1/4"	650 l/min	1000 l/min	1 - 10 bar	0,10 kg
DSVH-1/8	G 1/8"	230 l/min	360 l/min	1 - 10 bar	0,10 kg
DSVH-1/4	G 1/4"	650 l/min	1000 l/min	1 - 10 bar	0,10 kg

# PFF 520 701/PFFR 520 701

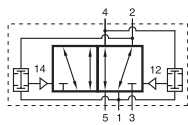

PFF 520 701

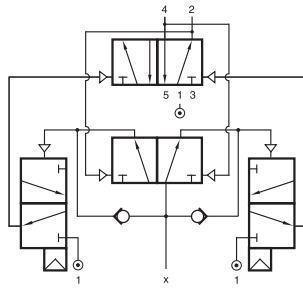

PFFR 520 701



Valves to generate oscillating movements for devices where continuous cycling is required, e.g. shaking, hammering, scraping, wiping, dipping etc.

**Oscillating valve type PFF 520 701:**

When compressed air is applied to port 1, the outlet ports 2 and 4 are alternately supplied with compressed air.

The valve always moves the position as soon as the cylinder has reached the end position and a back pressure is applied to the valve.

**Flip-Flop valve type PFFR 520 701:**

The PFFR is a bistable 5/2-way valve, which is operated by only one pilot port.

When a signal is applied to pilot port X, the valve is switching the position. It will remain in this position even if the signal is taken away.

When the pilot signal is applied to port X again, the valve will switch the position again.

The speed of the operated cylinder and thus the frequency can be adjusted by adding flow regulators to the exhaust ports 3 and 5 of the valve. Please ask for SVE-1/4.

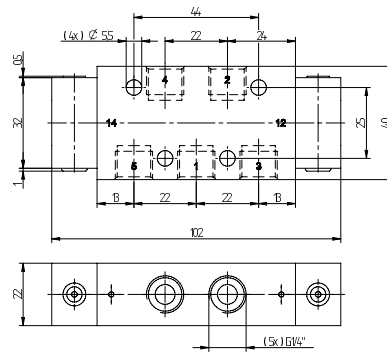

PFF 520 701

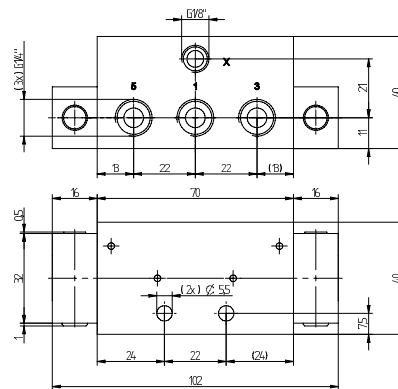

PFFR 520 701



SVE-1/4

Type	Port size	Air flow	Operating press.	Weight
PFF 520 701	G 1/4"	1250 l/min	2 - 10 bar	0,22 kg
PFFR 520 701	G 1/4"	1250 l/min	2 - 10 bar	0,40 kg

# DR 501/DR 801/DR 101 D 501/D 801/D 101

2.4.5.7  
page 75

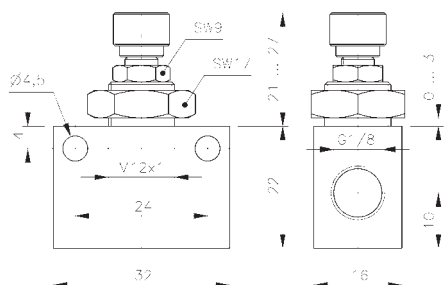

DR 501/D 501

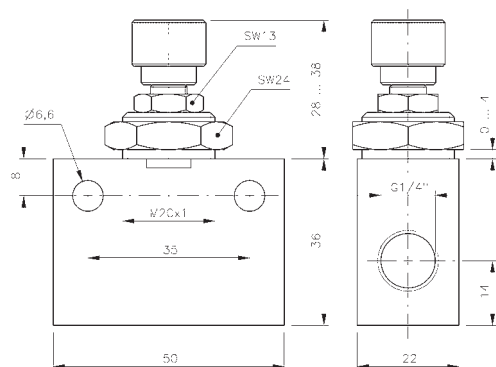

DR 801/D 801

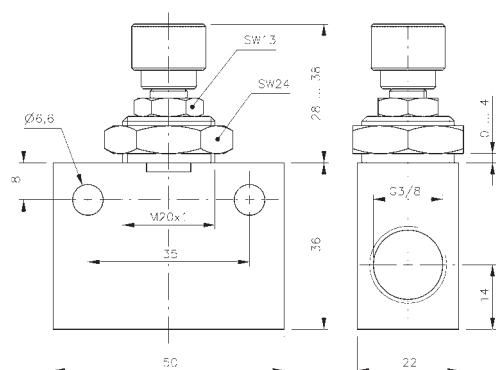

DR 101/D 101



Block form flow regulator.

Type DR  
uni-directional block form flow regulator.  
Air streaming in the direction of the throttle can be regulated by turning the spindle. In the opposite direction air streams unthrottled.

Type D  
bi-directional flow regulator. Air is regulated in both directions.

The throttle can be adjusted very precisely along the entire regulation range.

Adjustment can be locked.

Suitable for wall and panel mounting.  
Nut is included.

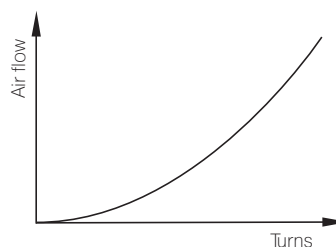

Type	Port size	Air flow*	Airflow in opposite direction*	Operating press.	Weight
D 501	G 1/8"	450 l/min	450 l/min	0,5 - 10 bar	0,04 kg ❄️
D 801	G 1/4"	1150 l/min	1150 l/min	0,5 - 10 bar	0,13 kg ❄️
D 101	G 3/8"	1450 l/min	1450 l/min	0,5 - 10 bar	0,13 kg
DR 501	G 1/8"	450 l/min	450 l/min	2 - 10 bar	0,04 kg ❄️
DR 801	G 1/4"	1150 l/min	1150 l/min	2 - 10 bar	0,13 kg ❄️
DR 101	G 3/8"	1450 l/min	1450 l/min	2 - 10 bar	0,13 kg

\* Values at 10 bar inlet pressure and without back pressure.

# D 181 G/D 181 0\_



D 181 G

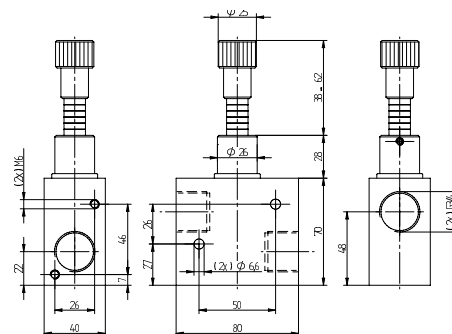

D 181 G

Block form flow regulator, bi-directional.  
Air is regulated in both directions.

Adjustment can be locked by a socket screw.  
7 coloured rings indicate the adjustment.

The flow regulator can either be used in-line or  
on a manifold plate. The following manifold  
sizes are available:

- D 181 02 2 stations, including flow regulators
- D 181 03 3 stations, including flow regulators

Temperature range: 0°C to 120°C.

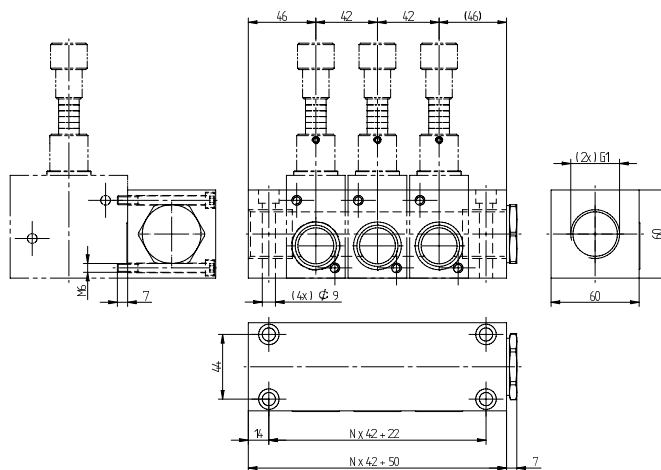

D 181 0\_

Type	Port size	Air flow*	Operating press.	Weight
D 181 G	G 3/4"	6000 l/min	0 - 10 bar	0,75 kg

\* Values at 10 bar inlet pressure and without back pressure.



# AND 204/OR 204/YES 204 NOT 204/RP LG 204

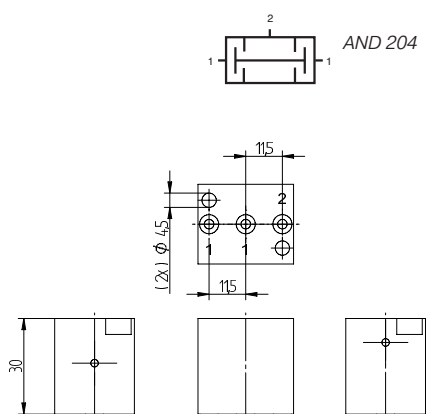

**AND 204/OR 204**

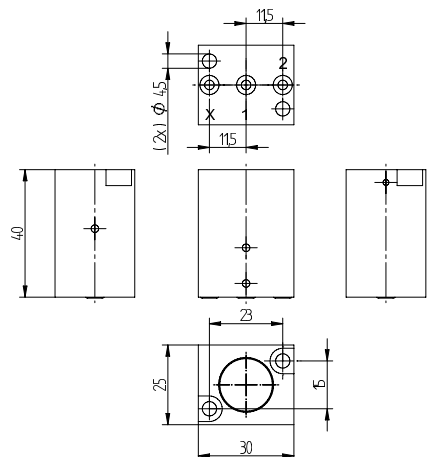

**YES 204/NOT 204**

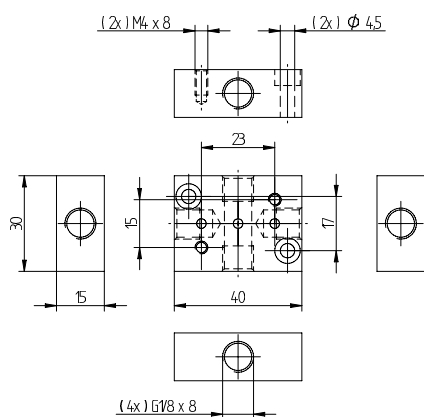

**RP LG 204**

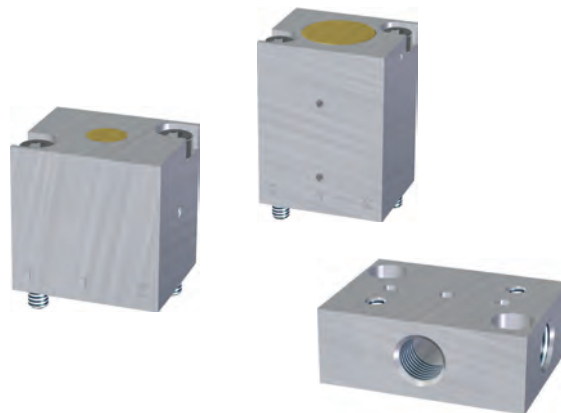
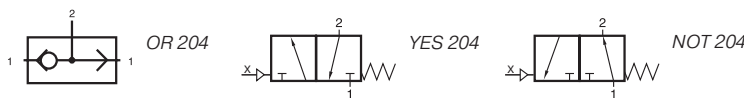

Logical elements with standardized interface used in commercial vehicle industries.

Elements can be mounted to subbase RP LG 204.

- AND 204: Gives output signal only when both input signals are present.
- OR 204: Gives output signal if either or both input signals are present.
- YES 204: The unit will give an output signal when there is an input signal present at port X.
- NOT 204: The unit gives an output signal when there is no input signal present at port X.

RP LG 204: Subbase for logical elements series 204 with 4 x G 1/8" ports.

Delivery of logical elements includes 2 screws and 3 O-Rings.

Type	Function	Port size	Air flow	Operating press.	Actuating press.	Weight
AND 204	OR	Ø 2 mm	100 l/min	1 - 10 bar		0,06 kg
OR 204	AND	Ø 2 mm	100 l/min	1 - 10 bar		0,06 kg
YES 204	N.C.	Ø 2 mm	100 l/min	1 - 10 bar	1 - 10 bar	0,08 kg
NOT 204	N.O.	Ø 2 mm	100 l/min	1 - 10 bar	1 - 10 bar	0,08 kg
RP LG 204		G 1/8"				0,08 kg

# P 310 304/P 311 304

# P 320 304/P 322 304/RP 3 344

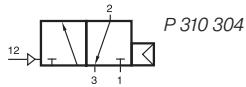

P 310 304

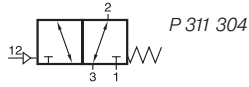

P 311 304

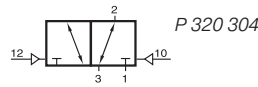

P 320 304

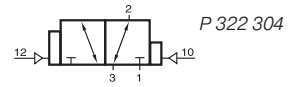

P 322 304

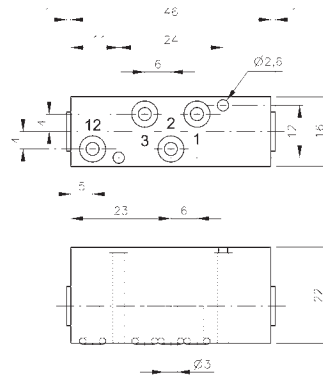

P 310 304/P 311 304

Pneumatically actuated 3/2-way spool valves.  
To be assembled to plate RP 3 344.

Four different versions are offered:

- P 310 304 valve with air-spring return
- P 311 304 valve with mechanical spring return  
Pressure applied to port 1 = YES-function  
Pressure applied to port 3 = NOT-function
- P 320 304 double pilot valve
- P 322 304 double pilot valve dominating at port 12

For P 310 304 the operating and actuating pressure should be at the same level.

RP 3 344 is designed for carrying one 3/2-way valve type P 310 304, P 311 304, P 320 304 or P 322 304. The plate is equipped with 5 push-in fittings for 4 mm tube.

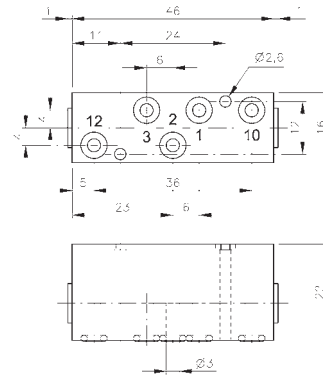

P 320 304/P 322 304

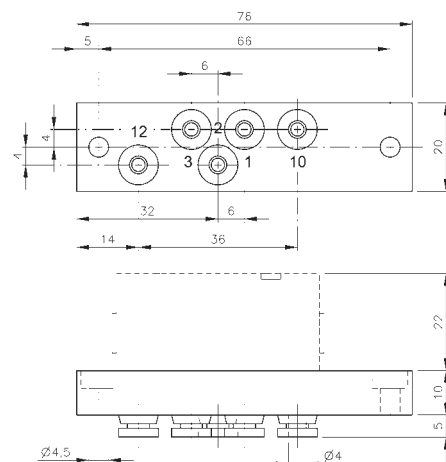

RP 3 344

Type	Port size	Air flow	Operating press.	Actuating press	Weight
P 310 304	Ø 3 mm	280 l/min	2 - 10 bar	the same	0,04 kg
P 311 304	Ø 3 mm	280 l/min	2 - 10 bar	3 - 10 bar	0,04 kg
P 320 304	Ø 3 mm	280 l/min	2 - 10 bar	2,5 - 10 bar	0,04 kg
P 322 304	Ø 3 mm	280 l/min	2 - 10 bar	2,5 - 10 bar	0,04 kg
RP 3 344	pif 4 mm				0,04 kg

# P 510 304/P 511 304 P 520 304/P 522 304/RP 5 344

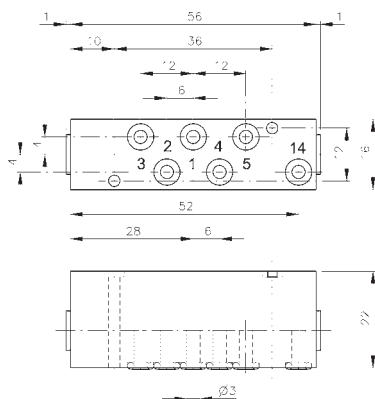
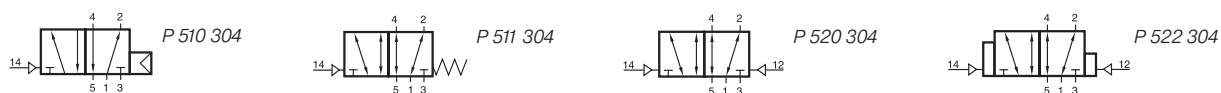

**P 510 304/P 511 304**

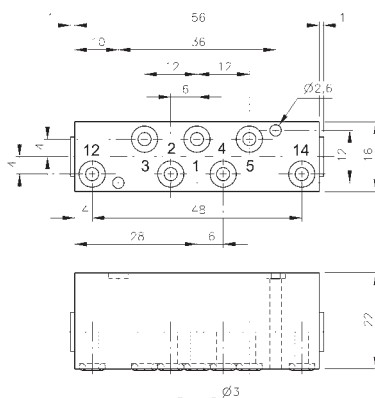

**P 520 304/P 522 304**

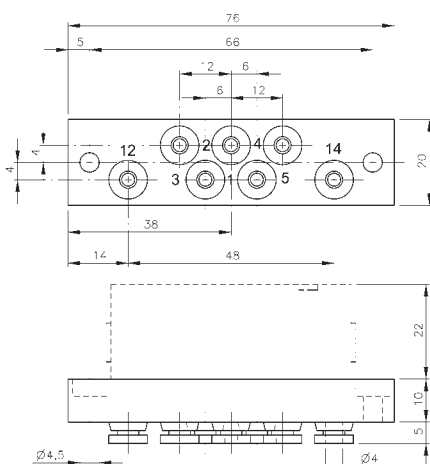

**RP 5 344**



Pneumatically actuated 5/2-way spool valves.  
To be assembled to plate RP 5 344.

Four different versions are offered:

- P 510 304 valve with air-spring return
- P 511 304 valve with mechanical spring return
- P 520 304 double pilot valve
- P 522 304 double pilot valve dominating at port 14

5/3-way valves are available on request.

For P 510 304 the operating and actuating pressure should be at the same level.

RP 5 344 is designed for carrying one piece 5-way valve type P 510 304, P 511 304, P 520 304 or P 522 304.

3/2-way valves can also be assembled to that plate. The plate is equipped with 7 push-in fittings for 4 mm tube.

Type	Port size	Air flow	Operating press.	Actuating press	Weight
P 510 304	Ø 3 mm	280 l/min	2 - 10 bar	the same	0,06 kg
P 511 304	Ø 3 mm	280 l/min	2 - 10 bar	3 - 10 bar	0,06 kg
P 520 304	Ø 3 mm	280 l/min	2 - 10 bar	2,5 - 10 bar	0,06 kg
P 522 304	Ø 3 mm	280 l/min	2 - 10 bar	2,5 - 10 bar	0,06 kg
RP 5 344	pif 4 mm				0,04 kg

# VA 304/ES 304/RP 2 344

2.4.6.4

page 80

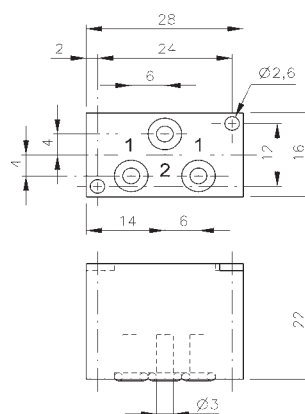
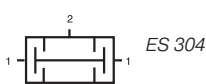
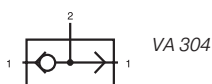

VA 304/ES 304

### VA 304: OR-gate

The OR-gate has two inputs 1 and one output 2.

The shuttle valve is used when only one of two possible signals is required to pass on a signal.

Function: If one of two signal inputs are activated, an output signal on port 2 is present and the other input is blocked.

In case of pressurising both inputs at different pressure levels, the higher pressure is fed to port 2.

### ES 304: AND-gate

The AND-gate has two inputs 1 and one output 2.

The dual-pressure valve is used when at least 2 signals are required before a signal is passed on.

Function: Only when both inputs are pressurised output 2 is pressurised.

If two different pressures are applied the lower pressure is fed to output 2.

In case of only one signal at one of the two ports 1, the output 2 is blocked.

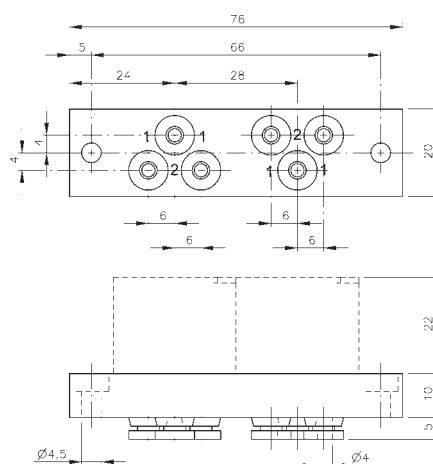

RP 2 344

Both elements can be assembled to RP 2 344. Plate can carry 2 pieces AND- or OR-gates. Both types can be mixed on the plate. The plate is equipped with 6 push-in fittings for 4 mm tube.

Type	Function	Port size	Air flow	Operating press.	Weight
VA 304	OR	Ø 3 mm	280 l/min	1 - 10 bar	0,03 kg
ES 304	AND	Ø 3 mm	280 l/min	1 - 10 bar	0,03 kg
RP 2 344	plate	pif 4 mm			0,04 kg

